

Modelling and Simulation of AC, DC and Hybrid AC-DC Microgrid with Battery Energy Storage

Zvonimir Šimić, Danijel Topić

Josip Juraj Strossmayer University of Osijek
Faculty of Electrical Engineering, Computer Science
and Information Technology Osijek
Kneza Trpimira 2b, 31000 Osijek, Croatia
{zvonimir.simic, danijel.topic}@ferit.hr

Anto Rogalo

Primary School Ivanja Reka
Ivanjorečka cesta 1b, 10373 Ivanja Reka, Zagreb,
Croatia
anto.rogalo@skole.hr

Abstract. A microgrid is a part of a distribution grid that can operate connected to the main grid and independent from the main grid. There are AC microgrids, DC microgrids, and hybrid AC-DC microgrids. The difference between these three topologies is the number of AC-DC converters. Modeling and simulation of these three main microgrid topologies and a comparison of simulation results are presented in this paper. The microgrid model consists of the photovoltaic power plant, wind turbine, battery energy storage, and two loads. Simulation results are presented so microgrid topologies can be compared and the most suitable topology can be selected.

Keywords. Microgrids, AC microgrid, DC microgrid, Hybrid AC-DC microgrid, Battery energy storage

1 Introduction

Trends in power systems are transformations from large-scale power grids where electrical energy is produced in large power plants and then transported over the transmission and distribution lines to customers to small-scale power grids where electrical energy is produced in distributed generation and used locally. Distributed generation is renewable energy sources (RES) based, which leads to reducing global warming and environmental pollution impact. In most cases, photovoltaic (PV) power plants which are suitable for mounting on the roofs of houses and buildings, are used. Production and use of electrical energy locally lead to reducing power losses due to energy transportation on long distances. Generation and use of electrical energy at the same location make a microgrid. The microgrid consists of a generation, consumption, and energy storage system, usually battery energy storage (BES).

There are different types of microgrids. Based on a number of energy sources, microgrid configurations can be classified as microgrid configurations based on two, three, or four energy sources (Rezkallah et al., 2019). There are centralized microgrids where all consumers are connected to one microgrid with a

central PV power plant and energy storage and standalone nanogrids where every consumer is equipped with their own PV power plant and energy storage (Werth et al., 2015):

Microgrids can be classified considering six criteria (Sahoo et al., 2021):

- Power form: AC and DC microgrids.
- Microgrid application: utility, industrial and remote microgrid.
- Microgrid structure: single-stage and two-stage.
- Supervise control: unified control and decentralized control.
- RES integration: converter and conventional DG-based microgrids.
- Operation mode: grid forming and grid following.

Microgrids can be classified according to three main criteria (Cabana-Jiménez et al., 2022).

- Demand criteria: simple, multi DG, and utility.
- Capacity criteria: simple, corporate, feeder area, substation area, and independent microgrids.
- Power criteria: DC, AC, and hybrid DC-AC.

This paper deals with the comparison of microgrids according to the power criteria and there are AC, DC, and hybrid AC-DC microgrids. Current distribution networks are AC so switching to an AC microgrid is very simple as it is with the development of microgrids in a rural areas (Zhu et al., 2019). AC microgrid is a suitable solution for grid operation mode and when the backup generator is used (Minemura et al., 2020). PV and batteries are DC while the utility grid and consumers are AC so there is a hybrid AC-DC microgrid that connects DC and AC sides with a bidirectional AC-DC converter (Gao et al., 2020). Fuel cells that have the potential to be a great power source in the future are DC, like batteries and PV so hybrid AC-DC microgrids will be a suitable solution in the future (Liang et al., 2018). Many devices today are charged with USB which is DC, LED lighting is DC, computer data centers require DC power distribution so with a high amount of DC load, production from PV power plants and BES has the sense to make a DC

microgrid (Ali et al., 2021). DC microgrids are suitable for commercial buildings with computers, data centers, LED lighting, EV charging stations, batteries, and PV power plants (Zhang et al., 2015).

The contribution of this paper is modeling and simulation of AC, DC, and hybrid AC-DC microgrid topologies for the same microgrid components sizes and comparison of results to find the most suitable topology for selected component sizes.

This paper consists of five chapters. The first chapter gives an introduction. Microgrids and microgrid topologies are described in chapter 2. Modeling of microgrid components is presented in chapter 3. Chapter 4 presents simulation results. The last chapter gives the conclusion of this paper.

2 Microgrids and microgrid topologies

A microgrid is a part of the distribution grid that can operate connected to the main grid and independent from the main grid. A microgrid is usually on a low voltage distribution grid but sometimes can be on medium voltage distribution grid. It can be only one building with a PV power plant on the roof or more buildings located closely. A microgrid can be for residential, commercial, or industrial consumers. Microgrids are suitable for rural areas or remote areas which are not connected to the A microgrid connects DGs and grid users at the same location in a small power system.

Microgrids have a positive impact on the environment and on the end customers. There are several advantages of microgrids as follows:

- Reducing the greenhouse gases emissions by producing electricity from RES.
- Reducing power losses due to the short distance the between production of electricity and consumption. There are no long power lines.
- Resistance to network disturbances.
- Ability to power consumption when the main grid is not available if there is enough energy storage capacity or backup generator.

Microgrid operation independent from the main grid presents a great challenge to ensure enough energy to cover whole consumption. There are several disadvantages of microgrids as follows:

- Requirements for battery energy storage systems which are still very expensive.
- Requirements for the backup generator which is very expensive to operate due to high fuel prices.
- Variability and intermittency of solar and wind energy.
- Load reducing if there is not enough battery capacity or backup generator when the main grid is not available.

According to the power criteria, there are AC, DC, and hybrid AC-DC microgrids. Differences between these three topologies are the type of power between components, the number of AC-DC converters, installed power, and efficiency of AC-DC converters.

2.1 AC microgrid

The distribution grid and most of the buildings are AC so it is a very easy switch to an AC microgrid. In an AC microgrid, components are connected to a central AC bus. AC components like a wind turbine, AC load, and grid are connected to AC bus directly while DC components like PV power plants, batteries and DC loads are connected to AC bus over DC-AC converters. The battery is connected over the bidirectional DC-AC converters. The topology of the AC microgrid is presented in Fig. 1.

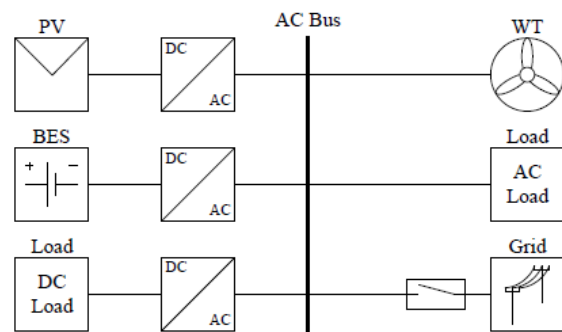

Figure 1. The topology of the AC microgrid

2.2 DC microgrid

DC microgrids are suitable for commercial buildings like data centers which require DC power distribution. In the DC microgrid, components are connected to the central DC bus. DC components like PV power plant, battery and DC load are connected directly to DC bus while AC components like wind turbine, and grid are connected to DC bus over AC-DC converters, and AC load is connected over DC-AC converter. The topology of the DC microgrid is presented in Fig. 2.

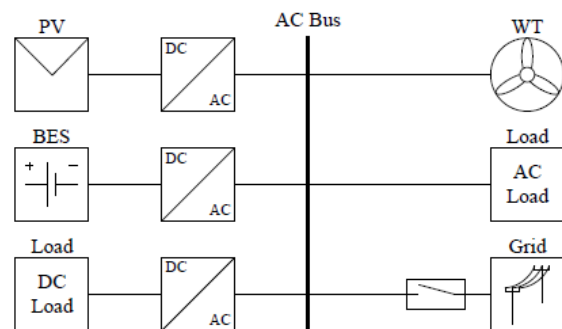

Figure 2. The topology of the DC microgrid

2.3 Hybrid AC-DC microgrid

In building with AC and DC loads and generation, hybrid AC-DC microgrids are a suitable solution. There are two buses, the AC bus, and the DC bus. AC components like a wind turbine, AC load, and grid are connected to the AC bus directly. DC components like PV power plant, battery, and DC load are connected directly to DC bus. AC bus is connected to the DC bus over the bidirectional AC-DC converter. The topology of the hybrid AC-DC microgrid is presented in Fig. 3.

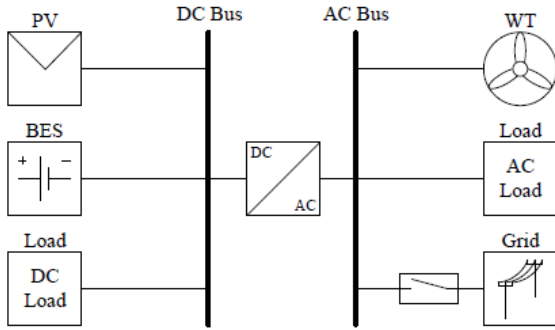

Figure 3. The topology of the hybrid AC-DC microgrid

3 Modeling of microgrid

In this chapter models of microgrid and microgrid components are described. The microgrid model in this paper consists of the PV power plant, wind turbine (WT), battery energy storage, AC load, DC load, and utility grid. These components are connected to the AC, DC and the hybrid AC-DC microgrids.

3.1 PV power plant

Generation from PV power plant is modeled according to measured solar irradiation data for the sunny day presented in Fig. 4. Generation from PV power plant starts at 4:00 and peak is at 12:00. Generation from PV power plant ends at 21:00.

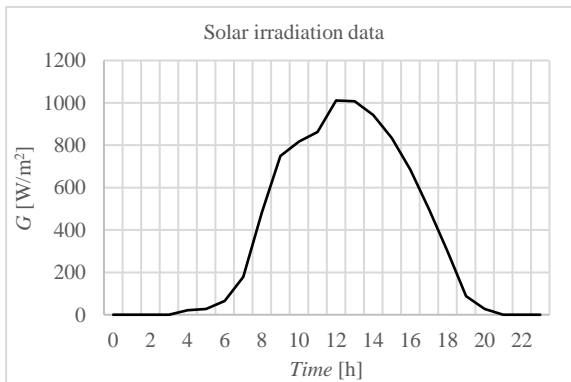

Figure 4. Solar irradiation data

One PV power plant consists of 40 PV modules with a maximum power of 250 W so the total installed power of one PV power plant is 10 kW. Module efficiency is 15.3% and dimensions are 1649x991 mm. When solar irradiation data is prepared, PV generation can be estimated according to eq. 1.

$$P_{pv,i} = n \cdot G_i \cdot A \cdot \eta \quad (1)$$

Where:

- n – number of PV modules;
- $P_{pv,i}$ [W] – PV generation in hour i ;
- G_i [W/m²] – solar irradiation in hour i ;
- A [m²] – area of one PV module;
- η – efficiency of a PV module.

3.2 Wind turbine

Generation from a wind turbine is modeled according to measured wind speed data for one day presented in Fig. 5. The rated power of wind turbine used in this model is 10 kW. Wind turbine height is 27 m, wind speed is measured at 10 m so wind speed data needs to be calculated at a height of 27 m according to eq. 2. Output power of the wind turbine can be estimated according to the wind turbine power curve presented in Fig. 6. The cut-in speed is 2 m/s, rated power is achieved at 9 m/s and the cut-off speed is 30 m/s.

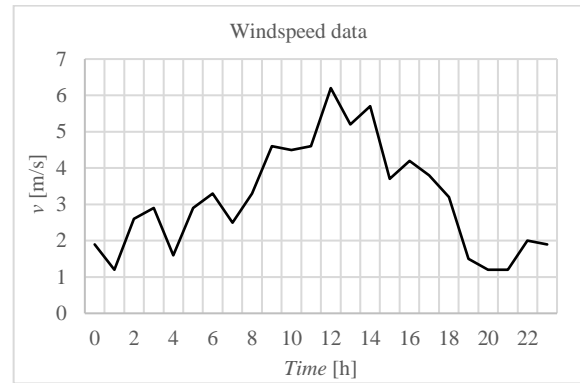

Figure 5. Wind speed data

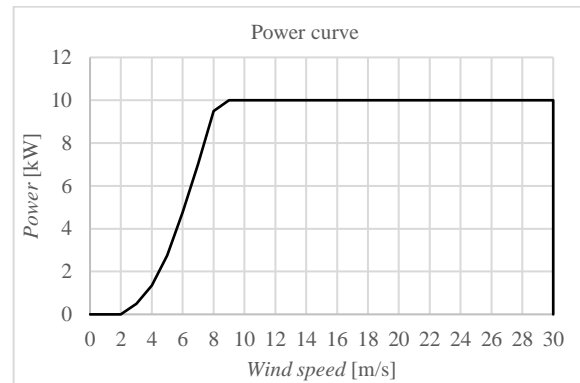

Figure 6. Wind turbine power curve

$$v_i = v_{0,i} \cdot (h / h_0)^\alpha \quad (2)$$

Where:

- v_i [m/s] – wind speed at height h in hour i ;
- $v_{0,i}$ [m/s] – wind speed at height h_0 in hour i ;
- h [m] – height of the wind turbine;
- h_0 [m] – height of wind speed measure equipment;
- α – friction coefficient.

3.3 Load

It is assumed that the microgrid model is for a residential area. There are two types of loads in the model, households and charging stations for electric vehicles (EV). AC load is modeled with measured load data which is scaled to microgrid size. The daily load diagram of AC load is presented in Fig. 7.

Minimal load demand is at 9:00 and peak load demand is at 20:00. The total daily AC load demand is 600 kWh. DC load is an EV charging station with a rated power of 50 kW. The daily load diagram of the EV charging station is presented in Fig. 8. Electric cars are connected to the EV charging station from 6:00 to 10:00, then from 16:00 to 18:00, and from 22:00 to 0:00. Electric cars are connected to the charging station 8 hours during the day so the daily load demand for the EV charging station is 400 kWh. The total daily load demand is 1000 kWh.

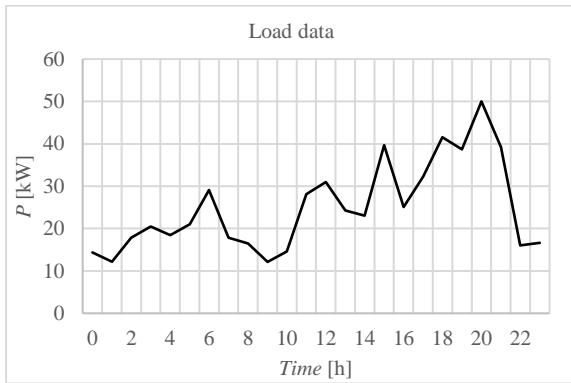

Figure 7. Load data

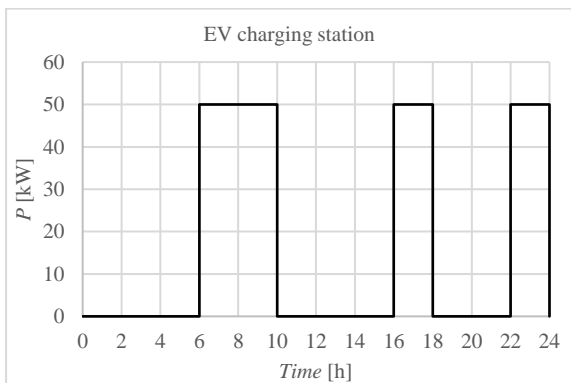

Figure 8. EV charging station

3.4 Battery energy storage

Battery storage is very important in microgrids to ensure enough energy to cover load demand during periods without solar and wind energy and if the main grid is not available. Battery energy storage used in this model is battery storage with a rated power of 50 kW and an installed capacity of 192 kWh.

Battery storage can be charged when there is an excess of energy generated from PV power plants or wind turbines and discharged when generation from PV power plants or wind turbines is lower than load demand. Battery storage also can be charged with electricity from the main grid during a period of low electricity prices.

4 Simulation results

The results of the simulations will be presented in this chapter. Simulations are done for AC, DC, and hybrid AC-DC microgrids during one working day. Electricity generation from the PV power plant is presented in Fig. 9, electricity generation from a wind turbine is presented in Fig. 10, and load profiles for AC and DC load are the same for all three microgrid topologies. Battery charging and discharging power, battery SOC and power received from the main grid are different for AC, DC, and hybrid AC-DC microgrid.

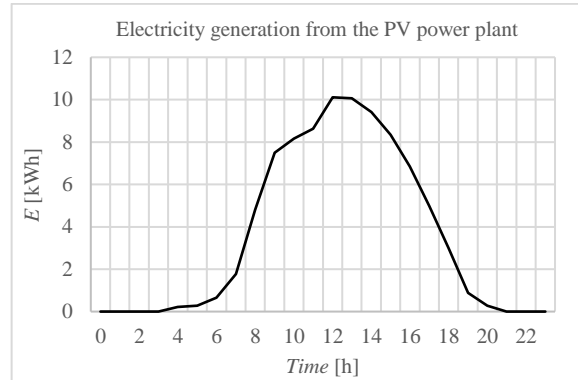

Figure 9. Electricity generation from PV power plant

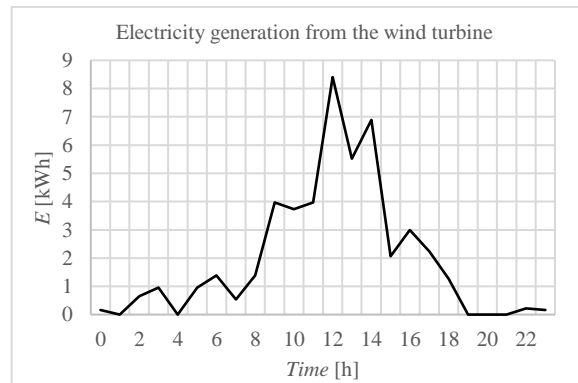

Figure 10. Electricity generation from wind turbine

Installed power of PV power plant and wind turbine, a number of PV power plants and wind turbines, daily generation, and total daily generation are presented in Table 1.

Table 1. The electricity generation in the microgrid

	PV power plant	Wind turbine
Power [kW]	10	10
Number of units	4	4
Daily generation of one unit [kWh]	85.945	47.472
Total daily generation [kWh]	343.78	189.89

The total daily generation from one PV power plant is 85.945 kWh. There are four PV power plants in the observed microgrid model so the total daily electricity generation from the PV power plants is 343.78 kWh. The total daily generation from one wind turbine is 47.472 kWh. There are four wind turbines in the observed microgrid model so the total daily electricity generation from the wind is 189.89 kWh. Two tariff electricity pricing model is considered in this microgrid simulation model. There is a higher day tariff with a price of 0.16 EUR/kWh and a lower night tariff with a price of 0.08 EUR/kWh. Day tariff starts at 8:00 and ends at 22:00 while night tariff starts at 22:00 and ends at 8:00.

4.1 Simulation of AC microgrid

In the AC microgrid there is a DC-AC converter that connects the DC PV power plant to the AC microgrid, then a bidirectional DC-AC converter that connects battery storage to the microgrid and enables charging and discharging of battery storage and an AC-DC converter that connects EV charging station to the AC microgrid. The efficiencies of DC-AC converter and bidirectional DC-AC converter are set to 0.92 and the efficiency of AC-DC converter is set to 0.87 (Atia et al., 2016).

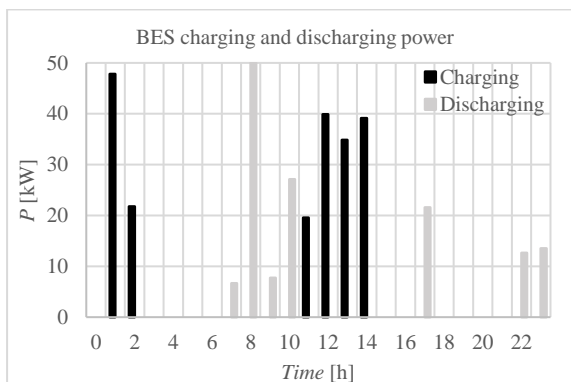

Figure 11. Charging and discharging power of BES in AC microgrid

The charging and discharging power of BES in the AC microgrid is presented in Fig. 11. It can be seen that battery is charging during night when electricity price is low and during day when there is a peak of generation from PV power plants and wind turbines. The battery is discharging in the morning when electric cars are connected to the EV charging station and when the electricity price is high.

4.2 Simulation of DC microgrid

In a DC microgrid, there is an AC-DC converter that connects the wind turbine to a DC microgrid, a DC-AC converter which connects the AC load to the DC microgrid and an AC-DC converter which connects DC microgrid to the main grid which is AC. The efficiencies of AC-DC converters are set to 0.87 while the efficiency of DC-AC converter is set to 0.92.

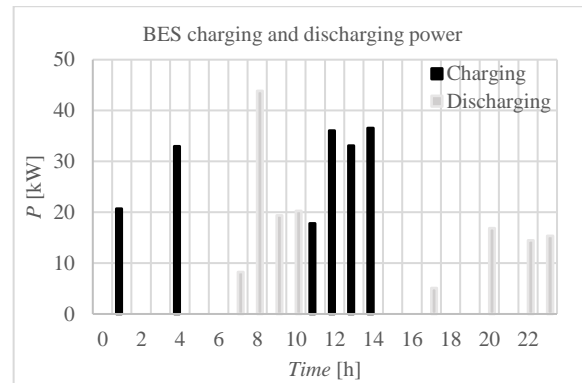

Figure 12. Charging and discharging power of BES in DC microgrid

The charging and discharging power of BES in the DC microgrid is presented in Fig. 12. It can be seen that the battery is charging during the night when the electricity price is low and during the day when there is a peak of generation from PV power plants and wind turbines. The battery is discharging in the morning to cover DC load demand and in the evening at 20:00 to cover peak AC load demand.

4.3 Simulation of hybrid microgrid

In a hybrid AC-DC microgrid, there is one large bidirectional AC-DC converter that connects the DC part of microgrid with the AC part of the microgrid. The efficiency of bidirectional converter is set to 0.9.

The charging and discharging power of BES in the hybrid AC-DC microgrid is presented in Fig. 13. It can be seen that the battery is charging during the night when the electricity price is low and during the day when there is a peak of generation from PV power plants and wind turbines. The battery is discharging in the morning to cover DC load demand and in the evening at 20:00 to cover peak AC load demand. The battery is also discharging at 22:00 and at 23:00 when the car is connected to an EV charging station.

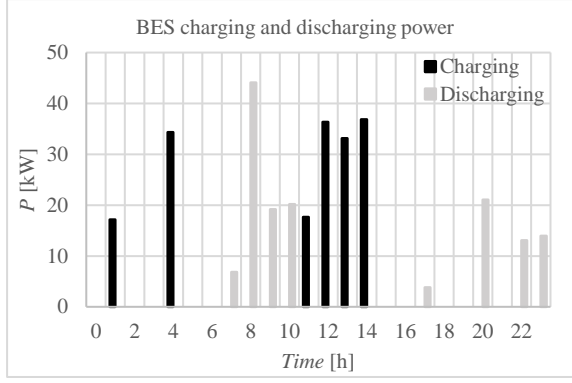

Figure 13. Charging and discharging power of BES in hybrid AC-DC microgrid

4.4 Comparison of simulation results

When simulations for AC, DC and hybrid AC-DC microgrids are done, results of the simulation can be compared. Fig. 14 presents a comparison of battery SOC for AC, DC, and hybrid AC-DC microgrids. Battery SOC at the start of the day is 50%. The battery in the AC microgrid is charged to 80% from 3:00 to 6:00 while batteries in DC and hybrid microgrids are charged up to 75%. Batteries in all three topologies are discharging from 6:00 to 10:00 and then charging from 10:00 to 14:00 when there is excess energy from PV power plants and wind turbines. Battery in all three topologies is charged to 80% from 14:00 to 16:00 and then battery in the AC microgrid is discharged to 66% while batteries in DC and hybrid microgrids are discharged to 77% and then discharged at 20:00 to cover peak load demand. Battery SOC at the end of the day is 50%.

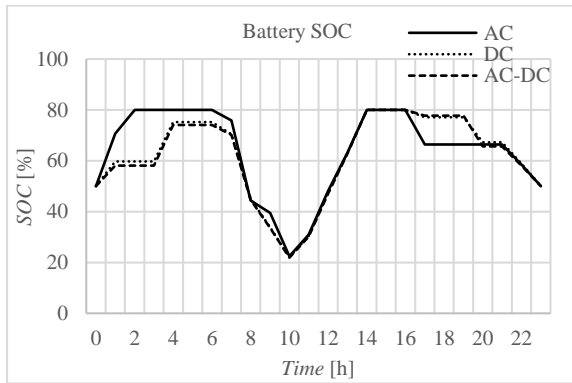

Figure 14. Comparison of battery SOC for AC, DC and hybrid AC-DC microgrid

Fig. 15 presents a comparison of electricity received from the grid for AC, DC, and hybrid AC-DC microgrids. Most electricity is received from the grid during the night when the electricity price is low and in the evening during periods of peak load demand. There is no electricity received from 10:00 to 14:00 due to electricity generation from PV and wind.

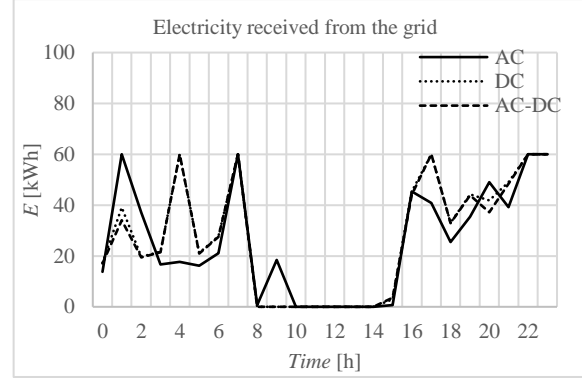

Figure 15. Comparison of electricity received from grid for AC, DC and hybrid AC-DC microgrid

A comparison of electricity received from the main grid, electricity cost, losses in a microgrid and overall microgrid efficiency for AC, DC, and hybrid AC-DC microgrids is presented in Table 2. Energy losses in microgrids occur because AC-DC and DC-AC power converters are not ideal. Energy losses in a microgrid can be calculated according to eq. 3.

$$E_{\text{losses}} = (E_{\text{pv}} + E_{\text{wt}} + E_{\text{grid}}) - E_{\text{load}} \quad (3)$$

Where:

- E_{losses} [kWh] – microgrid losses;
- E_{pv} [kWh] – generation from PV power plants;
- E_{wt} [kWh] – generation from wind turbines;
- E_{grid} [kWh] – electricity received from the grid;
- E_{load} [kWh] – total load demand;

The overall efficiency of a microgrid is a good indicator that is suitable for microgrid comparison (Manandhar et al., 2016). The overall efficiency of the microgrid can be calculated according to eq. 4.

$$\eta_{\text{microgrid}} = E_{\text{load}} / (E_{\text{pv}} + E_{\text{wt}} + E_{\text{grid}}) \quad (4)$$

Where:

- $\eta_{\text{microgrid}}$ – overall microgrid efficiency.

Table 2. Comparison of microgrid topologies

	AC	DC	Hybrid
PV [kWh]		343.78	
WT [kWh]		189.89	
AC load [kWh]		600	
DC load [kWh]		400	
Electricity [kWh]	617.43	663.06	650.35
Cost [EUR]	69.80	75.15	73.62
Losses [kWh]	151.10	196.73	184.02
Efficiency [%]	86.87	83.56	84.46

In the AC microgrid 617.43 kWh of electricity is received from the grid DC microgrid 663.06 kWh is received from the grid, and in the hybrid AC-DC microgrid 650.35 kWh of electricity is received from the grid. The cost for electricity in an AC microgrid is 69.80 EUR, in a DC microgrid cost for electricity is 75.15 EUR and in a hybrid AC-DC microgrid cost is 73.62 EUR.

Losses in AC microgrid are 151.10 kWh, in DC microgrid losses are 196.73 kWh and in hybrid AC-DC microgrid losses are 184.02 kWh. The overall efficiency of the AC microgrid is 86.87%, the overall efficiency of the DC microgrid is 83.56% and the overall efficiency of the hybrid AC-DC microgrid is 84.46%.

According to the simulation result, AC microgrid topology is most suitable for selected system components. It is because of high AC load demand, significant generation from wind turbines, and a significant amount of electricity received from the grid. DC microgrid topology would prove suitable if DC load demand was higher than AC load demand. Hybrid AC-DC microgrid topology has good efficiency due to significant generation from PV power plants and significant DC load demand.

5 Conclusion

Microgrids will be more and more present as a suitable solution for connecting distributed generation with consumers at same the location in a small independent power system. Three main topologies of microgrids according to the power between microgrid components of microgrid systems are AC microgrid, DC microgrid, and hybrid AC-DC microgrid. The difference between microgrid topologies is a number of AC-DC converters that are not ideal so there are power losses during power conversion.

AC microgrids are suitable for existing consumers which are largely AC and the transition from the existing power system to AC microgrid is very simple and fast. DC microgrids are suitable for applications with battery storage, generation from DC sources like PV power plants, and significant DC consumers like EV charging stations, computers, and LED lighting. Hybrid AC-DC microgrids with one bidirectional AC-DC converter are suitable for applications where DC generation and consumers and AC generation and consumers are equally represented.

Acknowledgments

This work was funded by the European Union through the European Regional Development Fund's Operational Programme Competitiveness and Cohesion under project KK.01.1.1.04.0034 Connected Stationary Battery Energy Storage.

References

- Ali, S., Zheng, Z., Aillerie, M., Sawicki, J. P., Péra, M. C., & Hissel, D. (2021). A review of DC microgrid energy management systems dedicated to residential applications. *Energies*, *14*(14), 1–26. <https://doi.org/10.3390/en14144308>
- Atia, H. R., Shakya, A., Tandukar, P., Tamrakar, U., Hansen, T. M., & Tonkoski, R. (2016). Efficiency analysis of AC coupled and DC coupled microgrids considering load profile variations. *2016 IEEE International Conference on Electro Information Technology (EIT), 2016-Augus*, 695–699. <https://doi.org/10.1109/EIT.2016.7535324>
- Cabana-Jiménez, K., Candelo-Becerra, J. E., & Santos, V. S. (2022). Comprehensive Analysis of Microgrids Configurations and Topologies. *Sustainability (Switzerland)*, *14*(3), 1–25. <https://doi.org/10.3390/su14031056>
- Gao, F., Wang, X., Yang, P., Kou, S., & Sun, M. (2020). Research and Simulation of Hybrid AC/DC Microgrid. *2020 4th International Conference on HVDC (HVDC)*, 1276–1280.
- Liang, B., Kang, L., Zhang, Z., Hu, B., Zhao, Y., Zhang, Z., & Yao, N. (2018). Simulation Analysis of Grid-connected AC/DC Hybrid Microgrid. *2018 2nd IEEE Conference on Energy Internet and Energy System Integration (EI2)*, 1–6.
- Manandhar, U., Ukil, A., & Jonathan, T. K. K. (2016). Efficiency comparison of DC and AC microgrid. *2015 IEEE Innovative Smart Grid Technologies - Asia, ISGT ASIA 2015*. <https://doi.org/10.1109/ISGT-Asia.2015.7387051>
- Minemura, K., Owaki, D., Yukita, K., Goto, Y., Ota, T., Miyoshi, H., Beibei, W., Yang, L., & Hirose, K. (2020). Study of a microgrid using a private power generator during a utility grid failure. *2019 IEEE Third International Conference on DC Microgrids (ICDCM)*, 1–6. <https://doi.org/10.1109/icdcm45535.2019.9232677>
- Rezkallah, M., Chandra, A., Singh, B., & Singh, S. (2019). Microgrid: Configurations, Control and Applications. *IEEE Transactions on Smart Grid*, *10*(2), 1290–1302. <https://doi.org/10.1109/TSG.2017.2762349>
- Sahoo, B., Routray, S. K., & Rout, P. K. (2021). AC, DC, and hybrid control strategies for smart microgrid application: A review. *International Transactions on Electrical Energy Systems*, *31*(1), 1–53. <https://doi.org/10.1002/2050-7038.12683>

- Werth, A., Kitamura, N., Matsumoto, I., & Tanaka, K. (2015). Evaluation of centralized and distributed microgrid topologies and comparison to open energy systems (OES). *2015 IEEE 15th International Conference on Environment and Electrical Engineering, IEEEIC 2015 - Conference Proceedings*, 492–497.
<https://doi.org/10.1109/IEEEIC.2015.7165211>
- Zhang, F., Meng, C., Yang, Y., Sun, C., Ji, C., Chen, Y., Wei, W., Qiu, H., & Yang, G. (2015). Advantages and challenges of DC microgrid for commercial building: A case study from Xiamen university DC microgrid. *2015 IEEE 1st International Conference on Direct Current Microgrids, ICDCM 2015*, 355–358.
<https://doi.org/10.1109/ICDCM.2015.7152068>
- Zhu, X., Premrudeepreechacharn, S., Sorndit, C., Meenual, T., Kasirawat, T., & Tantichayakorn, N. (2019). Design and Development of a Microgrid Project at Rural Area. *2019 IEEE PES GTD Grand International Conference and Exposition Asia, GTD Asia 2019*, 877–882.
<https://doi.org/10.1109/GTDAAsia.2019.8716001>